

# 125/32吨吊钩桥式起重机

E. O. T. Crane with Hook Cap. 125/32t

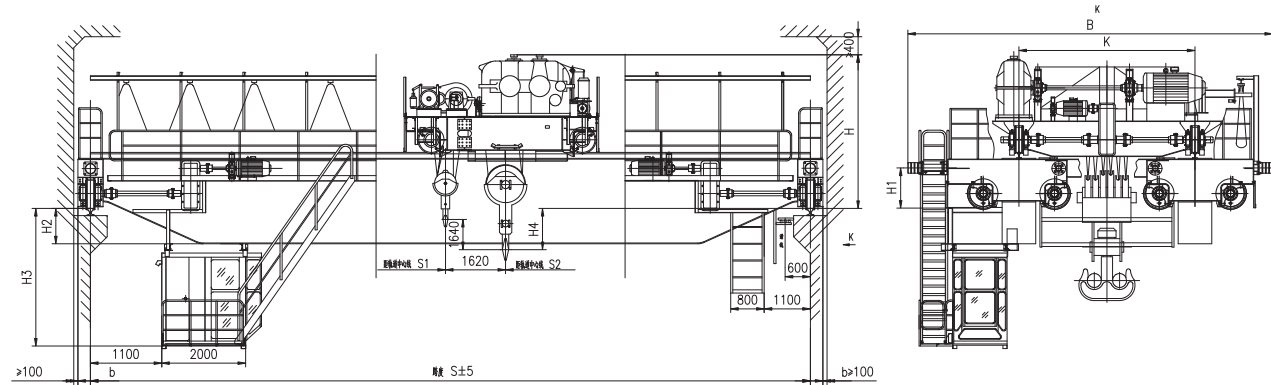

# 150/32-160/32吨吊钩桥式起重机

E. O. T. Crane with Hook Cap. 150/32-160/32t

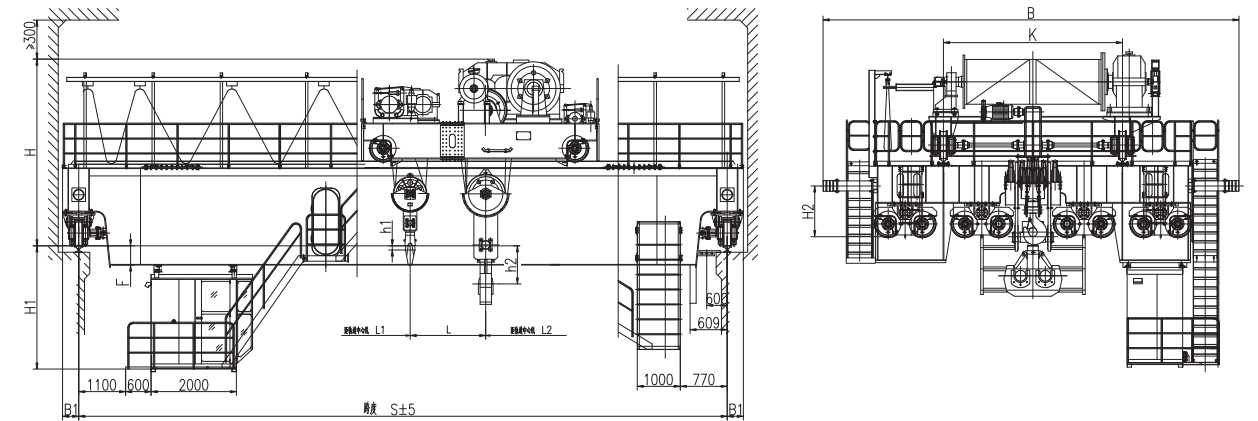

## 技术规格 Technical Specifications

起重量 Cap	主钩 Main	t	125														
	副钩 Aux.		32														
跨度 Span			13	16	19	22	25	28	31	13	16	19	22	25	28	31	
起升高度 Lifting Height	主钩 Main	m	18														
	副钩 Aux.		20														
工作制度 Duty			A5							A6							
速度 Speed	主起升 Main	m/min	3.5							3.6							
	副起升 Aux		7.5														
	小车运行 Crab travelling		33														
	大车运行 trolley travelling		59.56	59.2				59.7	67								
极限尺寸 limt dimension	S1		1200														
	S2		2500														
主要尺寸 main dimension	H	mm	3676	3676	3680	3682	3686	3686	3688	3676	3678	3682	3684	3688	3689		
	H1		950														
	H2		540	542	846	848	852	1052	1254	542	544	848	850	854	1054	1255	
	H3		2960	2962	3266	3268	3272	3472	3674	2962	2964	3268	3270	3274	3474	3675	
	H4		1560	1560	1556	1554	1556	1550	1548	1560	1588	1554	1552	1548	1548	1547	
	K		4400														
	B		8868				9008				8868				9008		
b	310																
最大轮压 Max.Wheel Loading	kN	388	408	430	445	459	470	492	390	410	432	445	462	476	489		
电机总功率 Span	kw	1795				197.5				194.5				210.5			
荐用钢轨 Crane Rail Recommended		QU100															
电源 Power Supply		三相交流 3-Phase A.C.50Hz 380V															

## 技术规格 Technical Specifications

起重量 Cap	主钩 Main	t	150							160							
	副钩 Aux.		32							32							
跨度 Span			13	16	19	22	25	28	31	13	16	19	22	25	28	31	
起升高度 Lifting Height		m	22							20							
			24							22							
工作制度 Duty			A5							A5							
速度 Speed	主钩 Main	m/min	3.7							3.2							
	副钩 Aux.		7.5							5.9							
	小车运行 Crab travelling		40							22.5							
	大车运行 trolley travelling		68	57													
极限尺寸 limt dimension	L1	mm	980							1392							
	L2		2500							2727							
	L		1700							1825							
	h2		1200	535				533									
	h1		50	240				238									
主要尺寸 main dimension	H	mm	4600							4496				4498			
	H1		3000				3150			2857				2957			
	B		9900							9900							
	K		4600							4400							
	B1		400							385							
	F		500				650			437				537			
最大轮压 Max.Wheel Loading	kN	262	283	294	304	312	319	326	272	293	300	315	324	331	338		
电机总功率 Span	kw	196	196	208	208	216	216	216	232				260				
荐用钢轨 Crane Rail Recommended		QU120							QU120								
电源 Power Supply		三相交流 3-Phase A.C.50Hz 380V							三相交流 3-Phase A.C.50Hz 380V								